



## Surface mounting enclosure



Powering Business Worldwide™

**Part no.** M22-11  
**Article no.** 216535  
**Catalog No.** M22-11Q

### Delivery programme

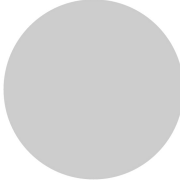
|                            |  |      |  |
|----------------------------|--|------|--|
| Product range              |  |      | RMQ-Titan (drilling dimensions 22.5 mm)  |
| Basic function             |  |      | Accessories  |
| Basic function accessories |  |      | Surface mounting enclosure   |
| Single unit/Complete unit  |  |      | Single unit  |
|                            |  |      | With high-grade steel screws   |
| Number of locations        |  | Qty. | 1  |
| Cable entry knockouts      |  |      |  |
| Cable entry                |  |      | at bottom: 2 x M16<br>at top: 1 x M20<br>lateral: 2 x M20/M25 (1 x each side)      |
| Colour                     |  |      |  |
|                            |  |      |  |
| RAL Value                  |  |      | RAL 7035   |
| Colour                     |  |      | Enclosure base anthracite  |
| Protection type            |  |      | IP67, IP69K  |
| Connection to SmartWire-DT |  |      | no   |

### Approvals

|                             |  |
|-----------------------------|--|
| Product Standards           | IEC/EN 60947-5; UL 508; CSA-C22.2 No. 14-05; CSA-C22.2 No. 94-91; CE marking |
| UL File No.                 | E29184   |
| UL Category Control No.     | NKCR   |
| CSA File No.                | 012528   |
| CSA Class No.               | 3211-03  |
| North America Certification | UL listed, CSA certified   |
| Degree of Protection        | UL/CSA Type 3R, 4X, 12, 13   |

### Technical data ETIM 5.0

Low-voltage industrial components (EG000017) / Enclosure for control circuit devices (EC000200)  
 Electric engineering, automation, process control engineering / Low-voltage switch technology / Command and alarm device / Housing for command and alarm devices  
 (eci@ss8-27-37-12-05 [AKF023010])

|                             |  |    |                          |
|-----------------------------|--|----|--------------------------|
| Number of command positions |  |    | 1                        |
| Construction type housing   |  |    | Surface mounting housing |
| Material housing            |  |    | Plastic                  |
| Diameter openings           |  | mm | 22                       |
| Colour housing cover        |  |    | Grey                     |
| Degree of protection (IP)   |  |    | IP67                     |
| Width                       |  | mm | 82                       |
| Height                      |  | mm | 72                       |
| Depth                       |  | mm | 74                       |

### Dimensions

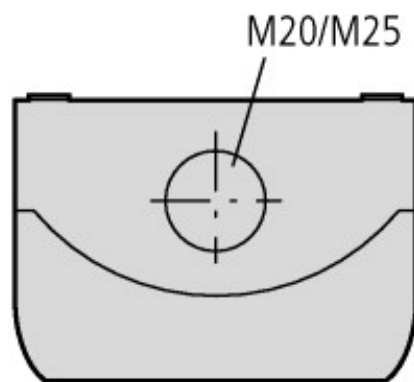
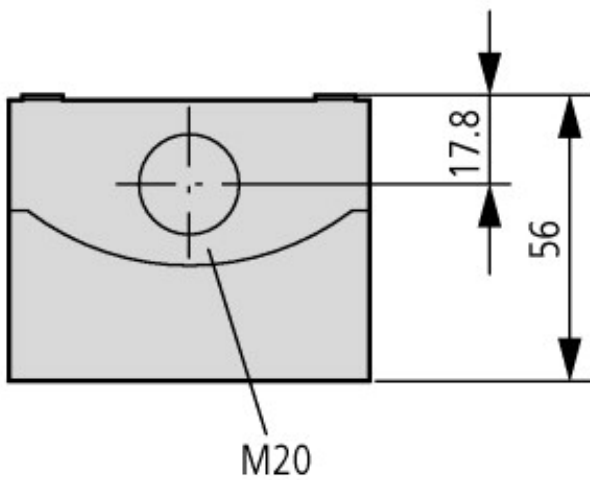
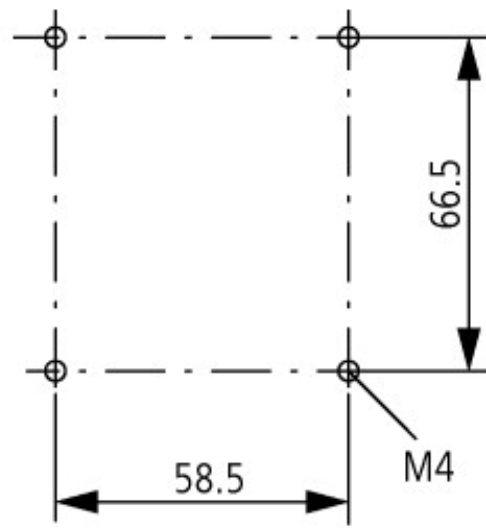
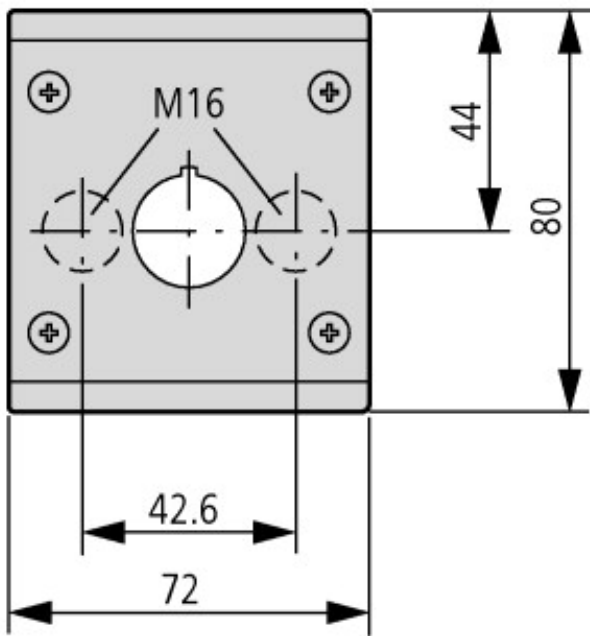

Premoulded cable entry: bottom 2 x M16, top: 1 x M20, side: 2 x M20/M25 (per side 1 x)

### Additional product information (links)

IL04716003Z (AWA1160-1746) RMQ-Titan System

IL04716003Z (AWA1160-1746) RMQ-Titan System

[ftp://ftp.moeller.net/DOCUMENTATION/AWA\\_INSTRUCTIONS/IL04716003Z2011\\_02.pdf](ftp://ftp.moeller.net/DOCUMENTATION/AWA_INSTRUCTIONS/IL04716003Z2011_02.pdf)