



## Surface mounting enclosure



Powering Business Worldwide™

**Part no.** M22-14  
**Article no.** 216539  
**Catalog No.** M22-14Q

### Delivery programme

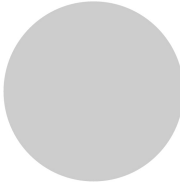
Product range			RMQ-Titan (drilling dimensions 22.5 mm)
Basic function			Accessories
Basic function accessories			Surface mounting enclosure
Single unit/Complete unit			Single unit
			With high-grade steel screws
Number of locations		Qty.	4
Cable entry knockouts			
Cable entry			at bottom: 2 x M20 at top: 2 x M20 lateral: 2 x M20/M25 (1 x each side)
Colour			
			
RAL Value			RAL 7035
Colour			Enclosure base anthracite
Protection type			IP67, IP69K
Connection to SmartWire-DT			no

### Approvals

Product Standards	IEC/EN 60947-5; UL 508; CSA-C22.2 No. 14-05; CSA-C22.2 No. 94-91; CE marking
UL File No.	E29184
UL Category Control No.	NKCR
CSA File No.	012528
CSA Class No.	3211-03
North America Certification	UL listed, CSA certified
Degree of Protection	UL/CSA Type 3R, 4X, 12, 13

### Technical data ETIM 5.0

Low-voltage industrial components (EG000017) / Enclosure for control circuit devices (EC000200)  
 Electric engineering, automation, process control engineering / Low-voltage switch technology / Command and alarm device / Housing for command and alarm devices  
 (ecI@ss8-27-37-12-05 [AKF023010])

Number of command positions			4
Construction type housing			Surface mounting housing
Material housing			Plastic
Diameter openings		mm	22
Colour housing cover			Grey
Degree of protection (IP)			IP67
Width		mm	186
Height		mm	56
Depth		mm	80

### Dimensions

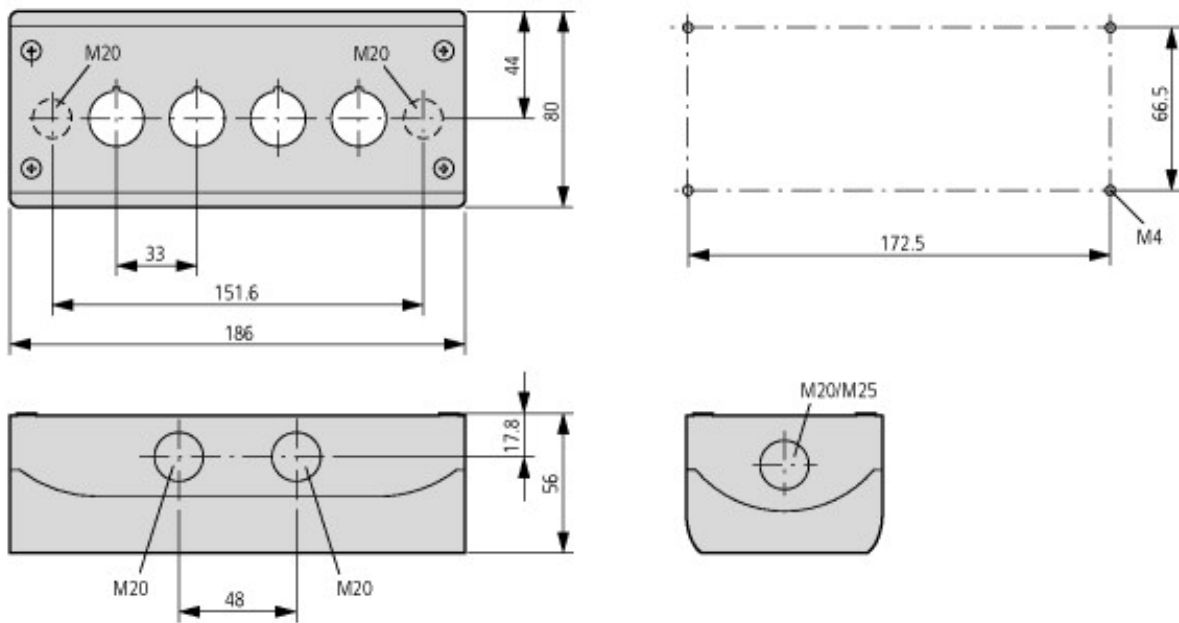

Premoulded cable entry: bottom 2 x M20, top: 2 x M20, side: 2 x M20/M25 (per side 1 x)

### Additional product information (links)

#### IL04716003Z (AWA1160-1746) RMQ-Titan System

IL04716003Z (AWA1160-1746) RMQ-Titan System

[ftp://ftp.moeller.net/DOCUMENTATION/AWA\\_INSTRUCTIONS/IL04716003Z2011\\_02.pdf](ftp://ftp.moeller.net/DOCUMENTATION/AWA_INSTRUCTIONS/IL04716003Z2011_02.pdf)